

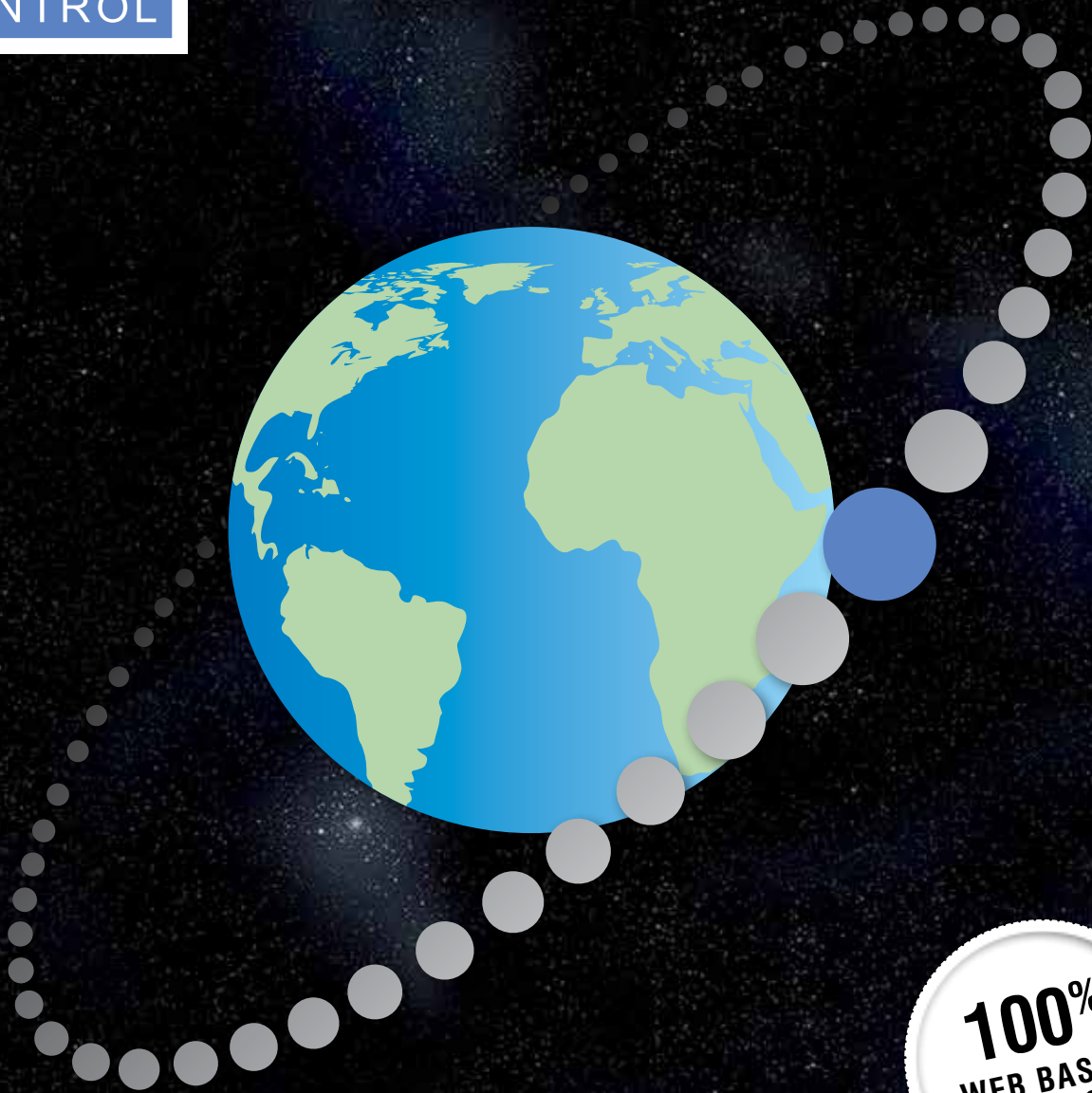

HALL 1 // STAND B1 40



MaxxControl - Monitor & Control

The first all web based monitoring system

www.maxxcontrol.com

Using the latest web technologies MaxxControl is the first system able to work in a browser window and independent from the operating system. Our solution is a combination of software and hardware entirely engineered by Antech team.

MaxxControl Monitoring & Control System

The MaxxControl Monitoring & Control System developed by Antech is a full web based software system providing monitoring and control of any kind satellite ground station and associated devices.

The system consists of three parts

- The MaxxHub Controller interfacing to the ground station equipment
- The MaxxControl Web interface, built in inside the controller
- The MaxxControl Server, which collect and stores the data of the several MaxxHub Controllers (optional)

The software is operating on any browser which has an acces via HTTP to the MaxxHub Controller and can work as stand-alone solution or as a newtork of MaxxHub Controllers all managed by a single web browser.

The main advantage of thus solution is the possibility to manage and monitor several ground stations both locally or from a central site.

Functionality of the MaxxControl System

The MaxxHub Controller monitors and controls the equipment of a satellite ground station. The monitoring is performed locally without any influence and connection of any operator client. The connected equipment is polled and monitored continuously. Typical alarm flags of the equipment, like summary alarm, lock alarm, etc., thresholds or limits of data quality are detected. The alarm message is stored in the internal MaxxHub Database and optionally at the MaxxControl Server and the operator is alerted via both a graphical and an audible alarm. The internal log database can easily be investigated and searched via a user-friendly interface for analysis and statistics. The operator has full control over all equipment and can monitor and change any device parameters without interruption of the service. Each device is represented in its own popup window with a simple click and multi-vendor equipment in the field can be supported with one single interface.



Events and alarms

View either current or historical events and alarms. Filter and sort alarms and events using various parameters. Map the alarm severity level to a corresponding physical

reaction in the system such as audible alarms and visual indicators. Navigate directly to the device window to get the details of the failure.

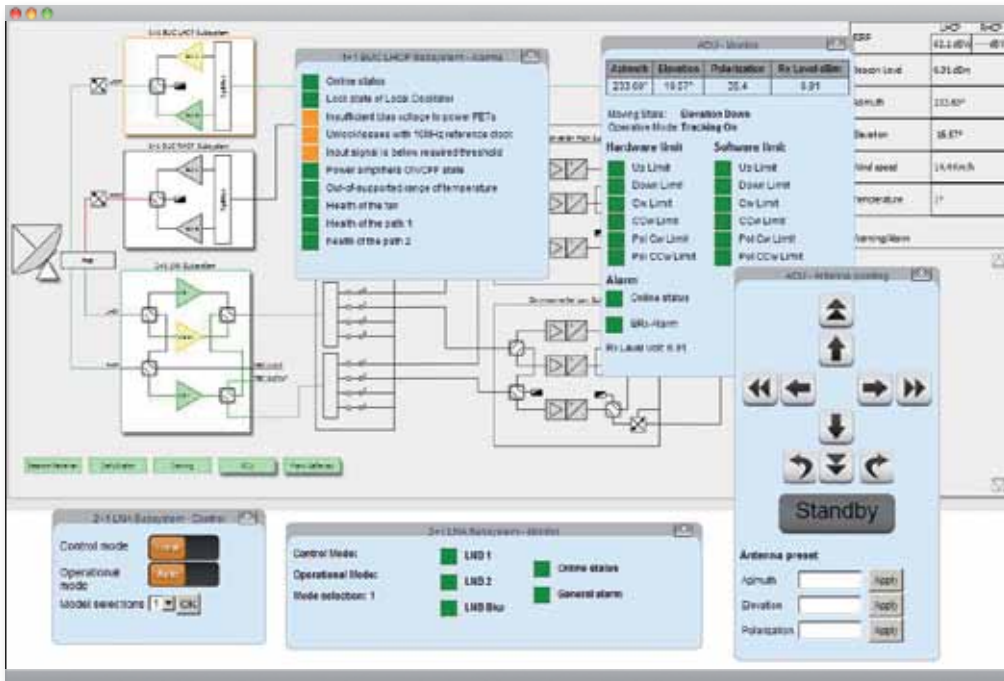

Redundancy management

MaxControl provides priority-based switching between online and standby equipment, based on pre-defined priorities assigned to each device, each workstation, each user and the system itself.

All switching criteria can be configured by the operator. All parameters for standby equipment being switched on-line are set to the same values as the equipment being switched out.

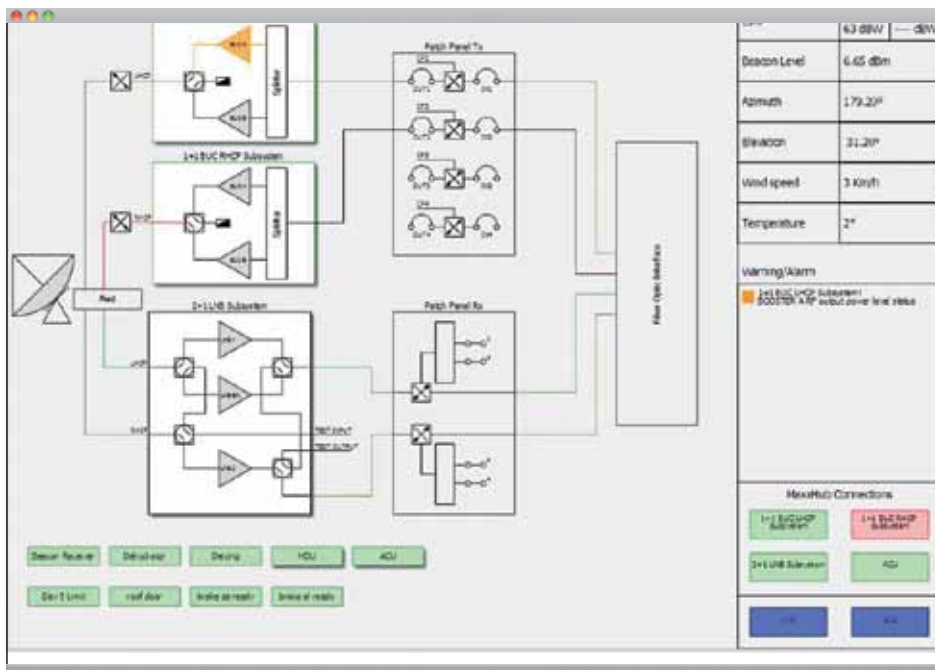

Main features

Web Based Graphical Software Architecture

1:N Automatic Switching

Cloud enabled: possibility to operate the system as a service

Complete scalability: run one or infinite system

Parameter and Alarm Logging

EIRP computed displa with value for each antenna based on the HPA output power level

Uplink Power Control

De-icing Management - with multiple antennas at one site, the system can schedule

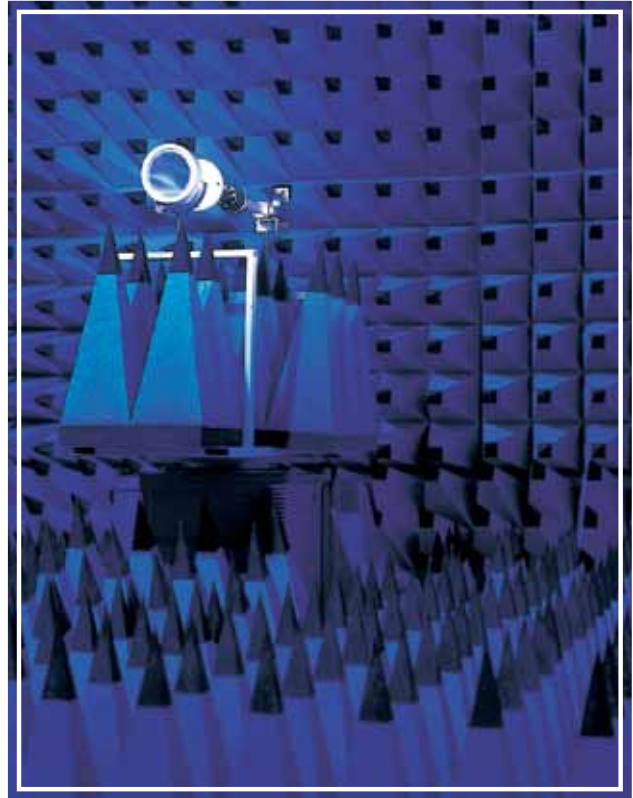

Key points

100% web based software interface

WebSocket Technology

Multi-tab support for multiple sites views

Full remote administration and support

Client is independent from Operating System

Unlimited number of clients possible

Event/Alarm log with filter utilities

Task- and device-oriented user interfaces

Macro recording functionality

Software configurable interface device configuration

CAD like screen configuration utility for user configurable operator screen contents



You can use iPad or smart phone to operate the system

Manage your system configuration and user access confidently

Today the management of Monitor and Control systems has become a significant challenge for IT staff which is continuously pressed to manage more computers, software configurations, networks always with fewer resources available. Thanks to MaxxControl unique Monitor and Control system one single installation of our platform can

manage all the installed systems without any specific competence of the IT Staff. This will simplify the overall management and will enable new staff to take care of the system without particular training, sensibly reducing the costs of the entire management of the clients equipments.



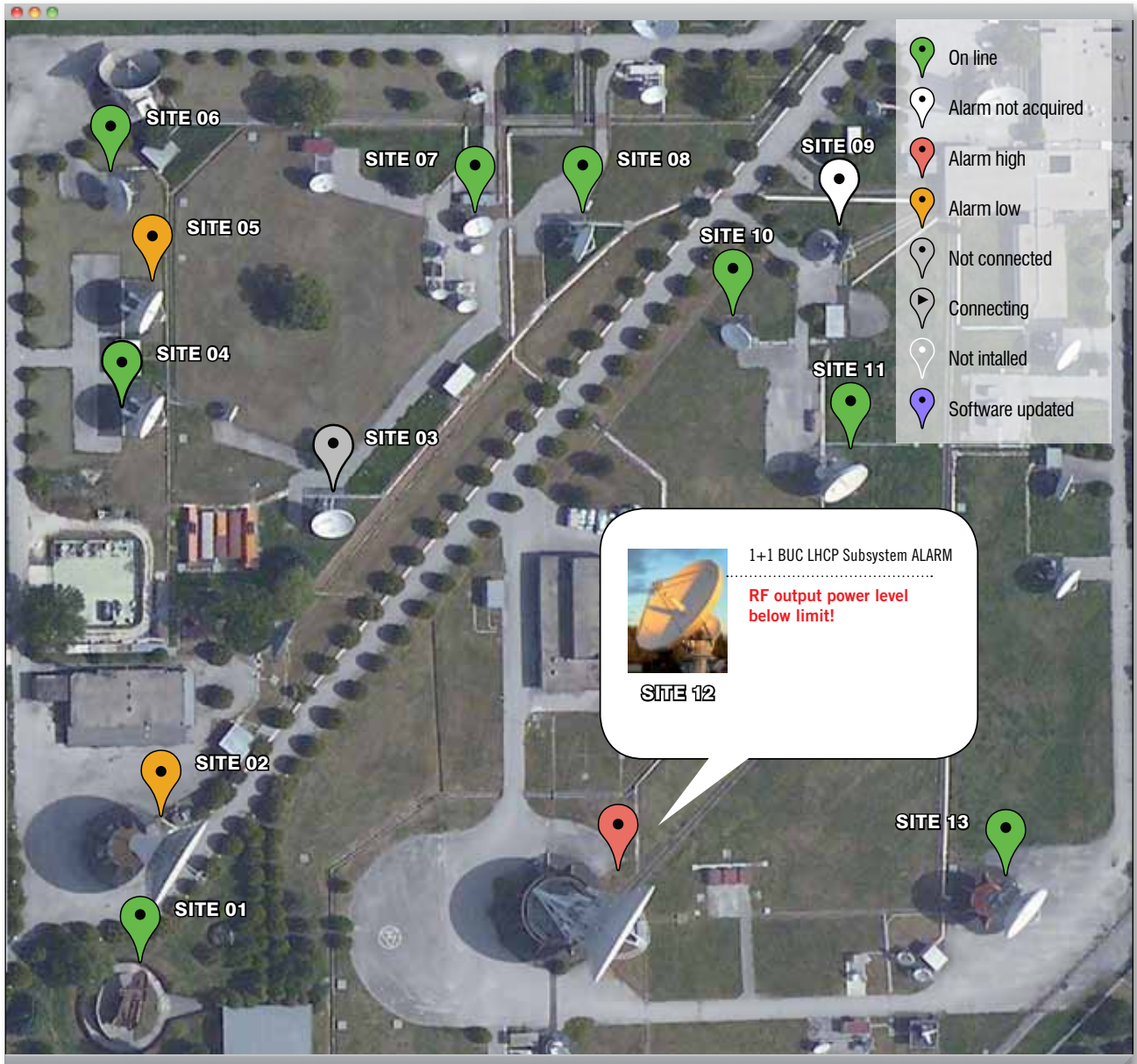

Graphical user interface

The user can monitor and control the sites via a graphical layout based on images from satellite with a style typical of Google Maps® interface

The user interface client software runs separately from the MaxxControl Server. This allows MaxxControl user interfaces to be run from multiple workstations and locations. All the equipment and sites in your network can be summarized in a single map view to assess your network status at a glance.



Technical Specification

Each MaxxHub System consists of an industrial PC based on latest hardware platforms designed for 19" rack mounting (1RU) with an Ethernet 10/100 Mbit interface and several serial interfaces RS232 or RS485/RS422. Multiple MaxxHub can be installed in parallel to extend the number of inputs/outputs.

Supported Satcom equipment interfaces

Serial interface RS232/RS485/RS422 on a 8P8C Rear Panel connectors.

Optocoupler inputs for Alarm Signals

Potential free Relay Output Contacts via MaxxControl IO-FEP

Ethernet Interface for overall Network Management

Electrical and mechanical specification, environmental conditions

Supply Voltage	110V/60Hz, 220V/50Hz, 20VA
Dimensions	19", 1RU x 480mm
Temperature Range	10° to 40° C
Humidity	Up to 90% non-condensing

Basic System Configuration

- 8 x RS232 or 8 x RS485 or 4 x RS422 max.
- 16 Input Signals
- 16 Output Signals
- 8 Analogue Signals
- Possibility to install multiple MaxxHub in parallel to extend potentially without limits the configuration

MaxxControl IO Frontend Processor

The MaxxControl IO-FEP interfaces to many "low level" interface commonly used in satellite ground stations like equipment alarm contacts and other status signals.

It provide opto-coupled inputs and potential free relay output contacts.

Web Browser Compatibility

- Google Chrome, version 24.0+
- Mozilla Firefox, version 17.0.1+
- Opera, version 12.12+

The MaxxHub





www.maxxcontrol.com



Antech S.p.A.
San Giovanni La Punta
Catania (Italy)

Tel: +39 095 741.74.00
Fax: +39 095 751.37.99
www.antech.it • info@antech.it



© Antech S.p.A., 2013 The copyright of this document is property of Antech S.p.A. This document is issued in confidence for the exclusive purpose for which it is supplied. It must not be reproduced, in whole or in part, or used for tendering or manufacturing purposes, except under an agreement or with the prior consent in writing of Antech S.p.A. For service assistance please contact: Antech S.p.A. Via V.E. Orlando, 7 95037 S.G. La Punta (Catania) Italy Tel. +39 095 7417400 Fax +39 095 7513799 E-mail info@antech.it